

BINKS® MODEL 80-294 1-QUART PRESSURE CUP FOR USE WITH MOST FULL SIZE SPRAY GUNS

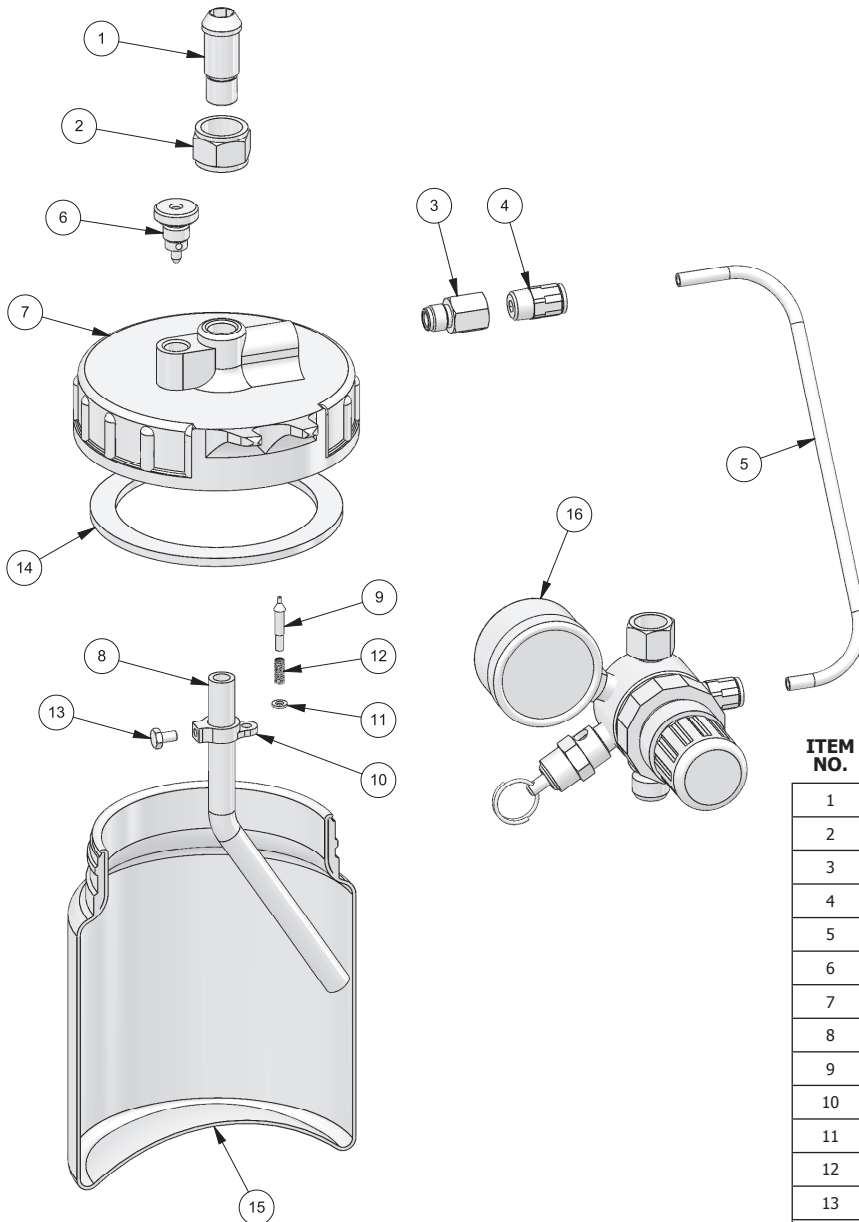

ITEM NO.	PART NO.	DESCRIPTION	QTY.
1	80-8	CENTERPOST	1
2	82-212	SWIVEL NUT	1
3	80-310	• ADAPTER	1
4	54-4945	• FITTING	1
5	82-731	• AIR TUBE	1
6	80-12	VENT KNOB	1
7	80-1	COVER MACHINING	1
8	57-120	MATERIAL TUBE	1
9	80-25	■ VALVE	1
10	80-24	■ BODY	1
11	57-125	■ * WASHER	1
12	80-26	■ * SPRING	1
13	20-6299	■ SET SCREW, HEX HD., 6-32 X 1/4 IN. LONG	1
14	80-11	GASKET	1
15	80-3	CUP	1
16	85-445	REGULATOR, COMPLETE	1

- TO REPLACE BRASS TUBE AND FITTINGS WITH NYLON TUBE AND FITTINGS, ORDER 80-311 RETROFIT KIT.
- ALSO AVAILABLE IN THE 80-27 CHECK VALVE KIT
- * AVAILABLE IN QUANTITY PACK. FOR WASHERS ORDER 57-125-5 (QTY. 5) FOR SPRINGS ORDER 80-26-5 (QTY. 5)

In this part sheet, the words **WARNING**, **CAUTION** and **NOTE** are used to emphasize important safety information as follows:





⚠ WARNING
 Hazards or unsafe practices which could result in severe personal injury, death or substantial property damage.

⚠ CAUTION
 Hazards or unsafe practices which could result in minor personal injury, product or property damage.

NOTE
 Important installation, operation or maintenance information.

⚠ WARNING

The following hazards may occur during the normal use of this equipment.
 Read the following chart before using this equipment.

HAZARD	CAUSE	SAFEGUARD
Spray 	Solvent and coatings can be highly flammable or combustible, especially when sprayed.	Adequate exhaust must be provided to keep air free of accumulations of flammable vapors Smoking must never be allowed in the spray area. Fire extinguishing equipment must be present in the spray area.
Solvent Spray 	During cleaning and flushing, solvents can be forcefully expelled from fluid and air passages. Some solvents can cause eye injury.	Wear eye protection.
Inhaling Toxic Substances 	Certain materials may be harmful if inhaled, or if there is contact with the skin.	Follow the requirements of the Safety Data Sheet supplied by your coating material manufacturer. Adequate exhaust must be provided to keep the air free of accumulations of toxic materials. Use a mask or respirator whenever there is a chance of inhaling sprayed materials and its concentration. Equipment must be as prescribed by an industrial hygienist or safety expert, and be NIOSH approved.
Explosion Hazard – Incompatible Materials 	80-296 is stainless steel and can be used with Halogenated Hydrocarbons. 80-294 & 80-295 are aluminum. Solvents such as 1, 1, 1- Trichloroethane and Methylene Chloride (sometimes called methyl chloride) can chemically react with the aluminum used in most spray equipment, and these cups, to produce an explosion hazard.	Read the label or data sheet for the material you intend to spray. Do not use any type of spray coating material containing these solvents with 80-294 or 80-295. Do not use these solvents for equipment cleaning or flushing with the 80-294 or 80-295. If in doubt as to whether a material is compatible, contact your material suppliers.



PROP 65 WARNING
 WARNING: This product contains chemicals known to the State of California to cause cancer and birth defects or other reproductive harm.

IT IS THE RESPONSIBILITY OF THE EMPLOYER TO PROVIDE THIS INFORMATION TO THE OPERATOR OF THE EQUIPMENT.
FOR FURTHER SAFETY INFORMATION REGARDING BINKS AND DEVILBISS EQUIPMENT, SEE THE GENERAL EQUIPMENT SAFETY BOOKLET (77-5300).

NOTES

WARRANTY POLICY

This product is covered by Carlisle Fluid Technologies' materials and workmanship limited warranty. The use of any parts or accessories, from a source other than Carlisle Fluid Technologies, will void all warranties. Failure to reasonably follow any maintenance guidance provided may invalidate any warranty.

For specific warranty information please contact Carlisle Fluid Technologies.

Carlisle Fluid Technologies is a global leader in innovative finishing technologies. Carlisle Fluid Technologies reserves the right to modify equipment specifications without prior notice.

DeVilbiss®, Ransburg®, ms®, BGK®, and Binks®
are registered trademarks of Carlisle Fluid Technologies, Inc.

©2018 Carlisle Fluid Technologies, Inc.
All rights reserved.

For technical assistance or to locate an authorized distributor,
contact one of our international sales and customer support locations.

Region	Industrial / Automotive	Automotive Refinishing
Americas	Tel: 1-800-992-4657 Fax: 1-888-246-5732	Tel: 1-800-445-3988 Fax: 1-800-445-6643
Europe, Africa, Middle East, India	Tel: +44 (0)1202 571 111 Fax: +44 (0)1202 573 488	
China	Tel: +8621-3373 0108 Fax: +8621-3373 0308	
Japan	Tel: +81 45 785 6421 Fax: +81 45 785 6517	
Australia	Tel: +61 (0) 2 8525 7555 Fax: +61 (0) 2 8525 7575	

For the latest information about our products, visit www.carlisleleft.com