

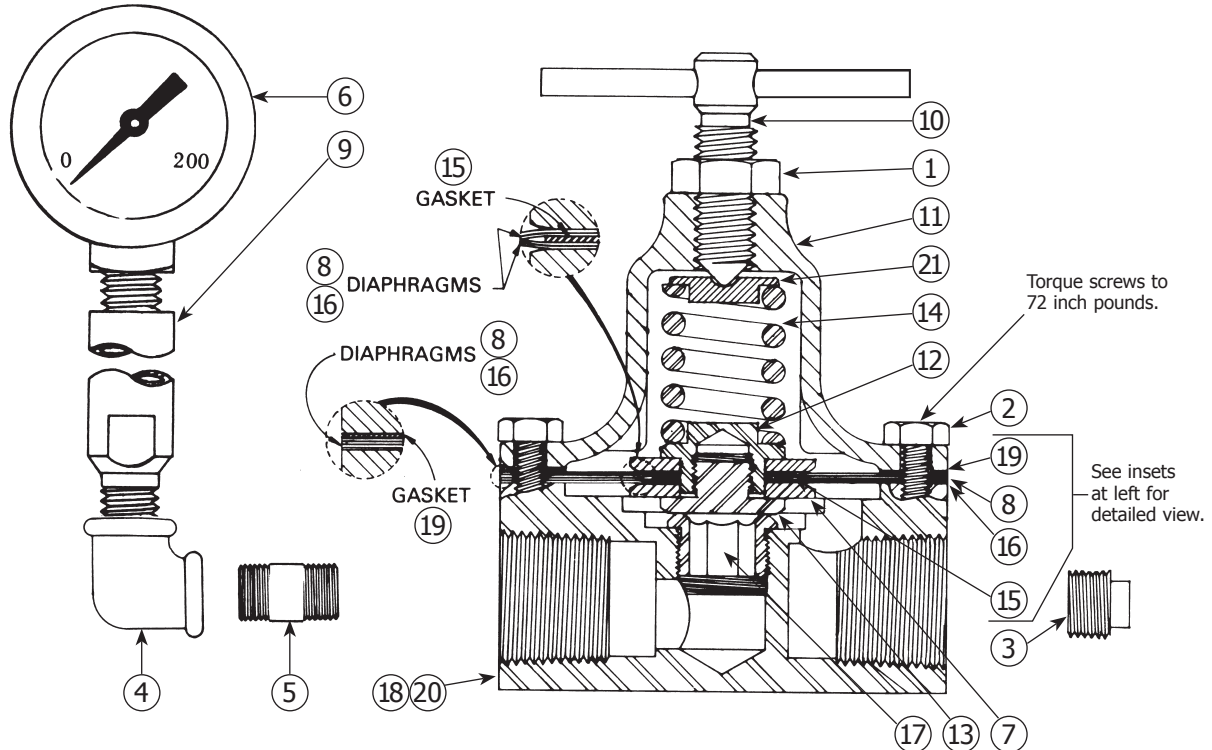

**MODELS 84-404 AND 84-504**  
**STAINLESS STEEL BACK PRESSURE FLUID VALVES**

**MODEL INLET & OUTLET FLOW COEFFICIENT**

84-404	3/4 NPT(f)	CV = 2.0 MAX.
84-504	1 1/4 NPT(f)	CV = 2.0 MAX.



**PARTS LIST**

When ordering, please specify Part No.

ITEM NO.	PART NO.	DESCRIPTION	QTY.
1	20-262	NUT, 1/2-13	1
2	20-783	SCREW, 1/4-20	6
3	20-4401	PLUG, 1/4 NPT	1
4	20-2848	ELBOW, 1/4 NPT	1
5	20-5632	NIPPLE, 1/4 NPT	1
6	83-2744*	GAUGE, 200 PSI	1
7	84-328	DISC	2
8	84-330▲	DIAPHRAGM, NYLON	2
9	84-348*	CONNECTOR	1
10	84-351	HANDLE	1
11	84-359	BONNET	1
12	84-362	RETAINER	1
13	84-363■	VALVE (84-404, 84-504)	1
14	84-365	SPRING	1
15	84-388▲	GASKET, VELLUMOID	1
16	84-399▲	DIAPHRAGM, PTFE	2
17	84-454■	SEAT (84-404, 84-504)	1
18	84-455	BODY, 3/4 NPT(f) (84-404)	1
19	84-463▲	GASKET, VELLUMOID	1
20	84-489	BODY, 1-1/4 NPT(f) (84-504)	1
21	85-10	BUTTON	1

\* Optional, not furnished. Please order separately.

▲ Also available in Soft Seal Repair Kit 6-1310.  
Kit not included, please order separately.

■ Also available in Valve Repair Kit 6-1312.  
Kit not included, please order separately.

**NOTE:** The following items are obsolete  
(refer to Part Sheet 1889R-7):

- 84-530 BACK PRESSURE VALVE
- 84-544 BACK PRESSURE VALVE

**SEE PAGE 3 FOR INSTRUCTIONS.**

In this part sheet, the words **WARNING**, **CAUTION** and **NOTE** are used to emphasize important safety information as follows:

## **WARNING**

Hazards or unsafe practices which could result in severe personal injury, death or substantial property damage.

## **CAUTION**

Hazards or unsafe practices which could result in minor personal injury, product or property damage.

## **NOTE**

Important installation, operation or maintenance information.

## **WARNING**

### Read the following warnings before using this equipment.



#### READ THE MANUAL

Before operating finishing equipment, read and understand all safety, operation and maintenance information provided in the operation manual.



#### OPERATOR TRAINING

All personnel must be trained before operating finishing equipment.



#### EQUIPMENT MISUSE HAZARD

Equipment misuse can cause the equipment to rupture, malfunction, or start unexpectedly and result in serious injury.



#### LOCK OUT / TAG-OUT

Failure to de-energize, disconnect, lock out and tag-out all power sources before performing equipment maintenance could cause serious injury or death.



#### AUTOMATIC EQUIPMENT

Automatic equipment may start suddenly without warning.



#### PRESSURE RELIEF PROCEDURE

Always follow the pressure relief procedure in the equipment instruction manual.



#### KEEP EQUIPMENT GUARDS IN PLACE

Do not operate the equipment if the safety devices have been removed.



#### KNOW WHERE AND HOW TO SHUT OFF THE EQUIPMENT IN CASE OF AN EMERGENCY



#### WEAR SAFETY GLASSES

Failure to wear safety glasses with side shields could result in serious eye injury or blindness.



#### INSPECT THE EQUIPMENT DAILY

Inspect the equipment for worn or broken parts on a daily basis. Do not operate the equipment if you are uncertain about its condition.



#### NEVER MODIFY THE EQUIPMENT

Do not modify the equipment unless the manufacturer provides written approval.



#### NOISE HAZARD

You may be injured by loud noise. Hearing protection may be required when using this equipment.



#### PROJECTILE HAZARD

You may be injured by venting liquids or gases that are released under pressure, or flying debris.



#### PINCH POINT HAZARD

Moving parts can crush and cut. Pinch points are basically any areas where there are moving parts.



#### STATIC CHARGE

Fluid may develop a static charge that must be dissipated through proper grounding of the equipment, objects to be sprayed and all other electrically conductive objects in the dispensing area. Improper grounding or sparks can cause a hazardous condition and result in fire, explosion or electric shock and other serious injury.



#### WEAR RESPIRATOR

Toxic fumes can cause serious injury or death if inhaled. Wear a respirator as recommended by the fluid and solvent manufacturer's Material Safety Data Sheet.



#### TOXIC FLUID & FUMES

Hazardous fluid or toxic fumes can cause serious injury or death if splashed in the eyes or on the skin, inhaled, injected or swallowed. LEARN and KNOW the specific hazards or the fluids you are using.



#### FIRE AND EXPLOSION HAZARD

Improper equipment grounding, poor ventilation, open flame or sparks can cause a hazardous condition and result in fire or explosion and serious injury.



#### MEDICAL ALERT

Any injury caused by high pressure liquid can be serious. If you are injured or even suspect an injury:

- Go to an emergency room immediately.
- Tell the doctor you suspect an injection injury.
- Show the doctor this medical information or the medical alert card provided with your airless spray equipment.
- Tell the doctor what kind of fluid you were spraying or dispensing.



#### GET IMMEDIATE MEDICAL ATTENTION

To prevent contact with the fluid, please note the following:

- Never point the gun/valve at anyone or any part of the body.
- Never put hand or fingers over the spray tip.
- Never attempt to stop or deflect fluid leaks with your hand, body, glove or rag.
- Always have the tip guard on the spray gun before spraying.
- Always ensure that the gun trigger safety operates before spraying.



CA PROP  
**65**

#### PROP 65 WARNING

WARNING: This product contains chemicals known to the State of California to cause cancer and birth defects or other reproductive harm.

**IT IS THE RESPONSIBILITY OF THE EMPLOYER TO PROVIDE THIS INFORMATION TO THE OPERATOR OF THE EQUIPMENT. FOR FURTHER SAFETY INFORMATION REGARDING THIS EQUIPMENT, SEE THE GENERAL EQUIPMENT SAFETY BOOKLET (77-5300).**

## BINKS STAINLESS STEEL BACK PRESSURE FLUID VALVES, MODELS 84-404 & 84-504

### MODEL INLET & OUTLET FLOW COEFFICIENT

84-404	3/4 NPT(f)	CV = 2.0 MAX.
84-504	1 <sup>1</sup> / <sub>4</sub> NPT(f)	CV = 2.0 MAX.

## INSTRUCTIONS

### INSTALLATION:

1. When installing back pressure valve assembly, make certain that ARROW underneath valve body points toward DOWNSTREAM side of system.
2. Make certain that inlet and outlet connections are tight.
3. If valve is installed in other than the upright (vertical) position, make certain that the gauge assembly (6) is in the upright position in all cases. The gauge assembly may be installed in either of the 1/4 NPT outlets.

### OPERATION:

1. With system in operation, turn handle (10) in a clockwise direction until desired back pressure or flow rate is obtained. To reduce back pressure, reverse procedure.
2. Tighten nut (1) to maintain desired back pressure.

### NOTE

**HIGHER back pressure REDUCES flow rate.**  
**LOWER back pressure INCREASES flow rate.**

3. If back pressure valve buzzes during or after initial startup of system, the presence of air in the system is indicated. If buzzing continues for any duration, reduce back pressure until buzzing ceases. Then readjust to desired back pressure.

### MAINTENANCE:

1. Back pressure valve can be serviced without removing the valve from the line.
2. To replace diaphragms, gaskets or seats:
  - a. Turn handle (10) in a counter-clockwise direction until tension from spring (14) is relieved.
  - b. Remove screws (2).
  - c. Remove valve (13).
3. To reassemble, reverse procedure as outlined. When reassembling, note sequence of diaphragms and gaskets. The gasket (15) fits between the diaphragms (8) and (16). The diaphragms are located below the other gasket (19). See detailed insets on diagram on page 1.

---

## WARRANTY POLICY

This product is covered by Carlisle Fluid Technologies' materials and workmanship limited warranty. The use of any parts or accessories, from a source other than Carlisle Fluid Technologies, will void all warranties. Failure to reasonably follow any maintenance guidance provided may invalidate any warranty.

For specific warranty information please contact Carlisle Fluid Technologies.

Carlisle Fluid Technologies is a global leader in innovative finishing technologies. Carlisle Fluid Technologies reserves the right to modify equipment specifications without prior notice.

DeVilbiss®, Ransburg®, ms®, BGK®, and Binks®  
are registered trademarks of Carlisle Fluid Technologies, Inc.

©2018 Carlisle Fluid Technologies, Inc.  
All rights reserved.

---

For technical assistance or to locate an authorized distributor,  
contact one of our international sales and customer support locations.

<b>Region</b>	<b>Industrial / Automotive</b>	<b>Automotive Refinishing</b>
Americas	Tel: 1-800-992-4657 Fax: 1-888-246-5732	Tel: 1-800-445-3988 Fax: 1-800-445-6643
Europe, Africa, Middle East, India	Tel: +44 (0)1202 571 111 Fax: +44 (0)1202 573 488	
China	Tel: +8621-3373 0108 Fax: +8621-3373 0308	
Japan	Tel: +81 45 785 6421 Fax: +81 45 785 6517	
Australia	Tel: +61 (0) 2 8525 7555 Fax: +61 (0) 2 8525 7575	

For the latest information about our products, visit [www.carlisleleft.com](http://www.carlisleleft.com)