

## MAPLE™ SERIES

Low Pressure and Medium Pressure  
Horizontal Piston Pumps

FLUID HANDLING

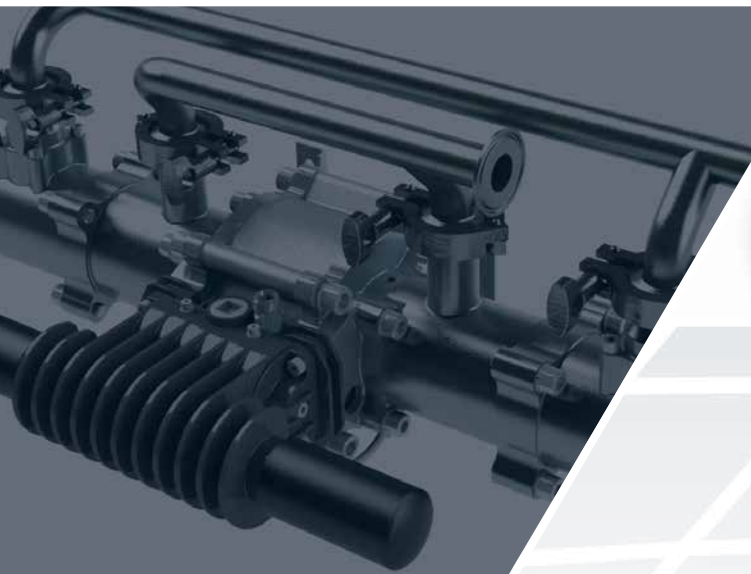

The Best Pump Solution for  
Pneumatic Circulation Systems and  
Medium Pressure Applications



# MAPLE SERIES

## Low Pressure and Medium Pressure Horizontal Piston Pumps

Binks Maple series are horizontal piston pumps used for circulation and spray gun feed applications. The pumps combine an energy efficient air motor with a low shear fluid section technology.

The patented air valve design includes a magnetic detent that reduces stall conditions. Binks Maple pump design has equal thrust on each piston stroke and quick pump change over reduces pressure fluctuations to a minimum.



### COATING TYPES AND APPLICATIONS

- Waterborne
- High Solids
- High Abrasives
- CARC
- UV Cured
- Solvent Borne
- Catalyst



CIRCULATION SYSTEMS



SPRAY GUN APPLICATIONS



FLATLINE MACHINERY

### BINKS MAPLE SERIES BENEFITS AND FEATURES

#### Handles Troublesome and Difficult Coatings

- High solids to CARC to UV.
- Moisture sensitive to shear sensitive.
- Both sides of fluid seal are flooded with fresh material.

#### Reliable Operation

- Backup seal means no need to shut down entire facility if a bellow seal fails. Keep on pumping until the next shift.
- Quick exhaust valve enables rapid switchover and smooth flow.
- Quick exhaust valve herds cooling/icing away from the air logic for the industry's most reliable motor.
- Tough Construction — pumps are made from hardened and chemically resistant materials including tungsten carbide, ceramic coated stainless steel, stainless steel, and fluoroplastic.

#### Simple to Maintain

- Inspection hose indicates when it's time to replace bellows.
- Backup seal ensures material doesn't enter air motor if bellows seal fails.
- No "upper seal" to keep lubricated or adjusted.

#### Hydraulically Efficient

- Piston seals are always engaged. If the air motor is consuming air, you're moving fluid, unlike some competitive designs.

# MAPLE SERIES

Low Pressure and Medium Pressure Horizontal Piston Pumps

## THE FINISHING INDUSTRY'S BEST AIR MOTOR

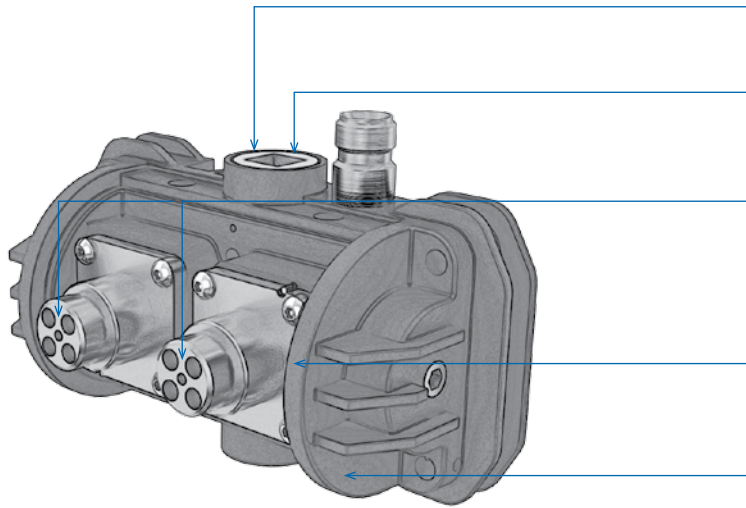

**Magnetic Detent Air Logic** requires less force to switch over. The result is smoother flow and lower minimum operating pressure.

**Lube-Free Air Logic.**

**Lubrication + Water + Dirt = Mud.**

The Maple pump uses no lubricant in the air logic and requires no external lubrication.

**Quick Exhaust Valve and Poppet-Actuated Air Logic Gives You Two Benefits:**

- If icing occurs, it is away from the air logic, virtually eliminating "stalling".
- Extremely quick switchover performance for smoother flow.

**Low-Ice Air Motor.** The Maple pump controls where any icing happens: away from the air logic. The result is the industry's most reliable air motor even with moist air.

**Easy to Maintain.** Repair air valve in 5 minutes.

## THE FINISHING INDUSTRY'S BEST FLUID SECTION

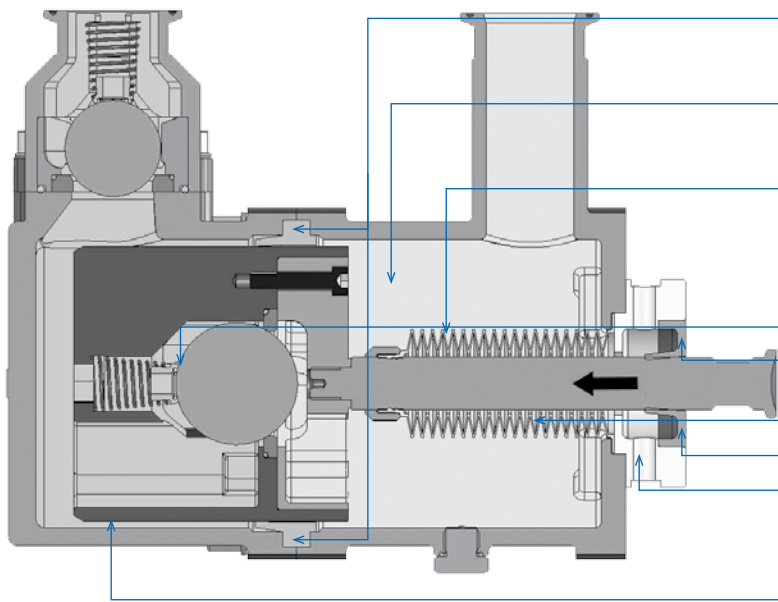

**Seal is Always Engaged** so you're always moving fluid. You'll consume significantly less air than you would if using a competitive design.

**Both Sides of Seal are Flooded with Fresh Material.**

Troublesome materials such as UV, waterborne, moisture sensitive or shear sensitive coatings simply aren't a problem.

**Binks Maple Pump "Run to Failure" Bellows System:**

- Has more convolutions than competition to minimize stresses and increase life.
- Is made of fluoroplastic with chemical resistance properties similar to PTFE.

**Lower Ball Check** in fluid piston.

**Backup U-Cup Seal.** When the bellows wear out, you won't contaminate the air motor!

**Bellows**

**Backup Seal**

**Visual Inspection Hose** attaches here. When you see material in the hose, it's time to change the bellows. But you can keep on pumping until the next shift!

**Ceramic Pistons and Tungsten Carbide Seats** give you the industry's best maintenance cycle.

# MAPLE SERIES

Low Pressure and Medium Pressure Horizontal Piston Pumps



## PUMP SPECIFICATIONS

	MAPLE 15	MAPLE 30	MAPLE 60	MAPLE 15 AFP*	MAPLE 15/6	MAPLE 7/15	MAPLE 8/25
Part #	104009-N	104010-N	104020	104129	104205-UK	104041-N	104042-N
Weight	46 lbs (21 kg)	66 lbs (30 kg)	145 lbs (66 kg)	55 lbs (25 kg)	91 lbs (45.5 kg)	57 lbs (26 kg)	88 lbs (40 kg)
Ratio	3:1	3:1	3:1	3:1	6:1	15:1	25:1
Flow @ 60 Cycles/Min	6 gal (23 liters)	12 gal (45 liters)	24 gal (91 liters)	6 gal (23 liters)	6 gal (23 liters)	2.6 gal (10 liters)	3.2 gal (12 liters)
Displacement/Cycle	375 cc/0.1 gal	750 cc/0.2 gal	1,500 cc/0.4 gal	375 cc/0.1 gal	375 cc/0.1 gal	166 cc/0.044 gal	200 cc/.053 gal
Inlet Fluid Connection	1" Sanitary	1 1/2" Sanitary	1 1/2" Sanitary	1" Sanitary	1" Sanitary	1" Sanitary	1" Sanitary
Outlet Fluid Connection	1" Sanitary	1 1/2" Sanitary	1 1/2" Sanitary	3/4" Sanitary	1" Sanitary	1/2" NPT Female	1/2" NPT Female
Max Fluid Pressure	300 psi (21 bar)	300 psi (21 bar)	300 psi (21 bar)	300 psi (21 bar)	600 psi (42 bar)	1,575 psi (109 bar)	2,625 psi (181 bar)
Air Consumption @ 45 psi	0.17 scfm/cycle	0.33 scfm/cycle	0.75 scfm/cycle	0.17 scfm/cycle	0.33 scfm/cycle	0.33 scfm/cycle	0.7 scfm/cycle
Max Air Inlet Pressure	100 psi (6.9 bar)	100 psi (6.9 bar)	100 psi (6.9 bar)	100 psi (6.9 bar)	100 psi (6.9 bar)	100 psi (6.9 bar)	100 psi (6.9 bar)
Max Recommended Continuous Cycle Rate	20 cpm	20 cpm	20 cpm	20 cpm	20 cpm	20 cpm	20 cpm

\*For use with piggyback systems with push and solvent air chop.

PART #	ACCESSORIES
<b>FILTERS</b>	
41-28283	100 Mesh Filter Kit Top Mount
41-28284	100 Mesh Filter Kit Rear Mount
<b>SURGE CHAMBERS</b>	
104050P-B-B	2" Sanitary Active Surge Eliminator
104050P-C-C	1 1/2" Sanitary Active Surge Eliminator
104050P-D-D	1 1/2" npt (Female) Active Surge Eliminator
104050P-L-L	1" Sanitary Active Surge Eliminator
104053-C-C	1 1/2" Sanitary Surge Chamber
104053-D-D	1 1/2" npt (Female) Surge Chamber
104053-L-L	1" Sanitary Surge Chamber

PART #	ACCESSORIES
107757	Low Shear Back Pressure Regulator, 3/4" Ports, Stainless Steel, No Gauge
<b>CONNECTION KITS FOR PUMPS:</b>	
502716	1 1/2" Sanitary x 1" npt (F) (2 Sets of Parts)
502717	1" Sanitary x 3/4" npt (F) (2 Sets of Parts)
502744	1" Sanitary x 3/4" npt (F) (1 Set of Parts)
502745	1 1/2" Sanitary x 1" npt (F) (1 Set of Parts)
41-28282	1" Sanitary x 1" npt (F) (1 Set of Parts)



### BINKS MAPLE SERIES 5-YEAR WARRANTY

Binks warrants to the original end-use purchaser that the Binks branded products "MAPLE" shall not fail under normal use and service due to a defect in material or workmanship within five (5) years from the date of shipment from Binks. Does not include normal wear and tear parts.

For further technical information please refer to the Binks Maple Service Bulletin.



SOLUTIONS FOR YOUR WORLD

[www.carlisleft.com](http://www.carlisleft.com)

World Class Manufacturers of: | Process Controls | Curing & Conveying  
Electrostatics | Fluid Handling | Powder Coating | Atomization

**Carlisle Fluid Technologies US**  
16430 N. Scottsdale Road, Suite 450  
Scottsdale, AZ 85254

Tel: 1-800-992-4657  
Fax: 877-790-6965  
Email: [ghcustserv@carlisleft.com](mailto:ghcustserv@carlisleft.com)