

# GFC-502 Aluminum Gravity Feed Cup

**Important:** Before using this equipment, read all safety precautions and instructions. Keep for future use.

**WARNING**

**Halogenated Hydrocarbon Solvents - for example: 1, 1, 1 - trichloroethane and methylene chloride can react with the aluminum in this cup and cause an explosion hazard. Read the data sheet for the material you intend to spray. Do not use spray materials containing these solvents with this cup.**

**DESCRIPTION**

120175 (GFC-502)                      32 oz. Cup

This cup is designed to be used with or without the DeVilbiss disposable cup liner. The cup liner allows painting in any position and simplifies clean up.

The cup is constructed from durable aluminum to provide trouble-free operation. The cup insert is electroless nickel plated brass. The disposable cup lid is recyclable and is constructed with recycled polyethylene. The lid has a unique drip check to prevent paint from dripping out of the vent in the lid.

**ASSEMBLY OF CUP TO GUN**

1. Remove one of the cup gaskets (#4 (Blue) for CVI, GTI, FLG, M1-G and Compact guns) from the poly bag.
2. Place this cup gasket in the fluid inlet of the gun body. See Cup Drawing.
3. Store remaining cup gasket in a safe place for future use.
4. Place filter (3) in cup outlet at this time if desired. See Cup Drawing.
5. Assemble cup to gun and tighten hand tight.

**FILLING WITH PAINT**

Fill the cup with paint to the full mark. Do not overfill.

**INSTALLING THE LID**

Place plastic lid on the top of the cup, and push in the center of the lid to assemble lid. Fold vent cap and push onto center portion of lid (if vent cap is not already assembled).

**CLEANING**

**Note**

For routine cleaning, it is not necessary to remove cup from gun. Do not remove washer (4) from gun. If washer (4) is removed, it must be replaced.

**CAUTION**

**Do not soak the lid in solvent for extended periods of time. Doing so could cause cup/lid sealing problems and leakage.**

**Cup Drawings**

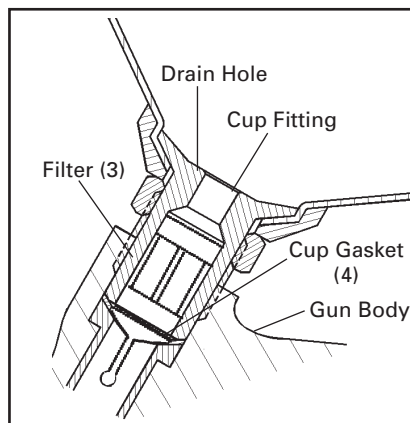

The cup lid is designed to be disposable but may be cleaned and reused if slightly contaminated with overspray. **If lid becomes tight, or does not fit, it is due to extended soaking in solvent. Let lid air dry overnight and the lid should return to its original size and fit.**

Remove lid and properly dispose of any excess paint. Pour in a small amount of clean solvent. The amount will vary with different coatings and solvents. Reinstall lid. Shake cup to wash down the inside surfaces. **Hold lid while shaking to prevent lid from coming off.** Pull trigger to allow some solvent to be flushed through gun. Remove lid and pour out dirty solvent. Add a small amount of clean solvent and repeat procedure. Wipe exterior of lid with a clean cloth and clean solvent.

If a paint filter was used in the bottom of the cup outlet, it should be removed and cleaned or replaced at this time. Dispose of used cup lid if contaminated and replace with new.

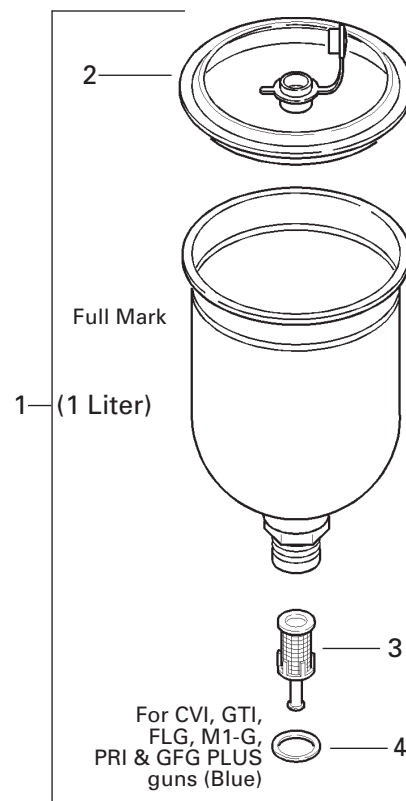

**PARTS LIST**

| Ref. No. | Replacement Part No. | Description                     |
|----------|----------------------|---------------------------------|
| 1        | GFC-502              | Metal Gravity Feed Cup (1Liter) |
| 2        | GFC-404-K2           | Disposable Lid Kit (Kit of 2)   |
| 3        | KGP-5-K5             | Filter Kit (Kit of 5)           |
| 4        | KGP-13-K5            | Cup Gasket (Blue) (Kit of 5)    |

## ACCESSORIES

**OMX-70-K48 PAINT CUP LINER KIT  
(Not for use with GFC-503 cups)**

Allows quick and easy clean-up.

**Consists of :**

- 1 - Piercing Tool
- 48 - Disposable Liners
- 48 - Drain Bushings

CA PROP  
**65****PROP 65 WARNING**

WARNING: This product contains chemicals known to the State of California to cause cancer and birth defects or other reproductive harm.

**WARRANTY POLICY**

DeVilbiss products are covered by Finishing Brands one year materials and workmanship limited warranty. The use of any parts or accessories, from a source other than Finishing Brands, will void all warranties. For specific warranty information please contact the closest Finishing Brands location listed below.

Finishing Brands reserves the right to modify equipment specifications without prior notice. DeVilbiss®, Ransburg®, BGK®, and Binks® are registered trademarks of Carlisle Fluid Technologies, Inc., dba Finishing Brands. ©2016 Carlisle Fluid Technologies, Inc., dba Finishing Brands. All rights reserved.

**DEVILBISS®**

DeVilbiss is part of Finishing Brands, a global leader in innovative spray finishing technologies. For technical assistance or to locate an authorized distributor, contact one of our international sales and customer support locations below.

**USA/Canada**

www.devilbiss.com  
info@carlisleleft.com  
Tel: 1-800-992-4657  
Fax: 1-888-246-5732

**Mexico**

www.carlisleleft.com.mx  
ventas@carlisleleft.com.mx  
Tel: 011 52 55 5321 2300  
Fax: 011 52 55 5310 4790

**Brazil**

www.devilbiss.com.br  
vendas@carlisleleft.com.br  
Tel: +55 11 5641 2776  
Fax: 55 11 5641 1256

**United Kingdom**

www.finishingbrands.eu  
info@carlisleleft.eu  
Tel: +44 (0)1202 571 111  
Fax: +44 (0)1202 573 488

**France**

www.finishingbrands.eu  
info@carlisleleft.eu  
Tel: +33(0)475 75 27 00  
Fax: +33(0)475 75 27 59

**Germany**

www.finishingbrands.eu  
info@carlisleleft.eu  
Tel: +49 (0) 6074 403 1  
Fax: +49 (0) 6074 403 281

**China**

www.finishingbrands.com.cn  
mkt@carlisleleft.com.cn  
Tel: +8621-3373 0108  
Fax: +8621-3373 0308

**Japan**

www.ransburg.co.jp  
overseas-sales@carlisleleft.co.jp  
Tel: 081 45 785 6421  
Fax: 081 45 785 6517

**Australia**

www.finishingbrands.com.au  
sales@carlisleleft.com.au  
Tel: +61 (0) 2 8525 7555  
Fax: +61 (0) 2 8525 7500

DEVILBISS®

Ransburg®

BGK®

BINKS®

Finishing Brands®

A CARLISLE COMPANY