

DEVILBISS® HGB FLUID REGULATORS

Important: Before using this equipment, read all safety precautions and instructions. Keep for future use.

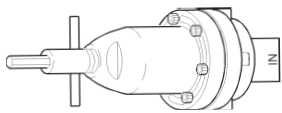

Model HGB-502-1
Regulator Assembly
Only

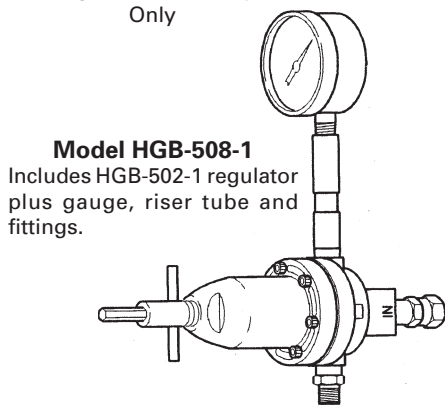

Model HGB-508-1
Includes HGB-502-1 regulator plus gauge, riser tube and fittings.

SPECIFICATIONS:

Height: 5" (excluding adjusting key)
Width: 2-7/8"
Wetted parts: Stainless steel/nylon

Inlet Pressure		Regulated Outlet Press.	Max. Fluid Flow	Connections
Max.	Min.			
175 psi	50 psi	10-75 psi	8 gal./min.	3/8" NPT(F)

Maximum temperature 180°F.

INSTALLATION

The HGB regulator is provided with two side outlet ports and one bottom inlet port, all 3/8" NPT(F). The regulator may be installed either vertically or horizontally for flexibility of installation. In either case, riser and gauge should be mounted vertically. The HGB-508 includes gauge, riser tube and fittings factory installed.

Since the gauge operates on air trapped in the riser, a rise is always necessary. Any leaks in riser or gauge connections will permit this trapped air to escape thus allowing paint to get into the gauge causing damage.

⚠ CAUTION

It is recommended that at initial installation the material supply line should not be flushed through the regulator because pipe compound, chips, scale, etc., may lodge in the regulator valve assembly.

See "ACCESSORIES" section for connections for riser, gauge, adapter and ball valves.

OPERATION

Fluid pressure adjustment is done with a removable key (1). Insert large end of key into top of regulator. Turn clockwise to increase fluid pressure, counterclockwise to decrease fluid pressure.

Fluid pressure adjustment can also be accomplished remotely with air control:

1. Turn adjusting key (1) fully counterclockwise turning the regulator off.
2. Remove adjusting key (1).
3. Install a 1/4" NPT(M) fitting H-2008 for air hose connection.
4. Use a regulated air supply to adjust fluid pressure regulator.

PREVENTIVE MAINTENANCE

Periodic cleaning of regulator with a solvent compatible with the material being used is recommended.

To clean material from the regulated material line and the regulator, these steps should be followed:

1. Relieve supply line pressure.
2. Using the small end of the adjusting key (1), engage the regulator and screw it down tight. This holds the valve off its seat. Also, the key may be used in this position to prevent waste from entering the regulator when spray booth is cleaned.
3. Blow material back through the regulated line by introducing air pressure into the line down stream from the regulator. With spray gun attached, this can be done by loosening air cap ring on gun, holding cloth over air cap and pulling trigger. This forces air in a reverse path through spray

gun and air forces material back through regulated material line.

4. Periodically clean exterior of regulator with solvent soaked cloth.

PARTS REPLACEMENT

The HGB regulator may be serviced without removing it from the line.

Note

Relieve line pressure before servicing regulator.

Remove six socket head cap screws (2) with a 5/32" hex key. The small end of the adjusting key (1) may be used for this purpose.

To Replace Diaphragm:

1. The diaphragm socket (B) has an arrow stamped on top. Curl the edge of the diaphragm up where the arrows point.
2. Slip the diaphragm assembly out from under the valve stem nut (C) so the nut is released from the socket (B).
3. Remove nut (A) and pull off diaphragms (7). Install 2 new diaphragms over threaded end of the socket (B). Convex sides of each diaphragm must be toward threaded end.
4. Apply retaining compound to male threads as shown and install nut (A).
5. Install diaphragm into body by again curling the edges of the diaphragms.
6. Slip socket (B) under valve stem nut (C).
7. Reassemble regulator body. Tighten all six cap screws evenly to 65 to 75 in./lbs. torque.

To Replace Valve Assembly:

1. Valve assembly (9) can be removed from the body with a 3/4" socket wrench.
2. Install new valve assembly. Tighten valve assembly to 20 to 25 in./lbs. torque.

TROUBLESHOOTING		
CONDITION	CAUSE	CORRECTION
Regulated pressure creep.	Improper seating of valve stem on seat. Diaphragm leaking. Damaged valve seat.	Be sure stem and seat are not damaged, worn or dirty. Replace. Replace seat and stem.
Regulated pressure drop.	Restriction in main material line or at valve inlet. Damaged diaphragm.	Remove restriction. Replace.
Fluid leakage from under bonnet.	Loose cap screws (2). Damaged diaphragm.	Tighten all six cap screws evenly to 65 to 75 in./lbs. torque. Replace.

Product Description/Object of Declaration: Fluid Regulators - HGB-502-1, HGB-508-1

This Product is designed for use with: Solvent and Water based Materials

Suitable for use in hazardous area: Zone 1

Protection Level: II 2 G

Notified body details and role: Element Materials Technology. WN8 9PN UK
Lodging of Technical file

This Declaration of Conformity /incorporation is issued under the sole responsibility of the manufacturer: Carlisle Fluid Technologies,
320 Phillips Ave.,
Toledo, OH 43612

EU Declaration of Conformity



The object of the declaration described above is in conformity with the relevant Union harmonisation legislation:

Machinery Directive 2006/42/EC
ATEX Directive 2014/34/EU

by complying with the following statutory documents and harmonized standards:

EN ISO 12100:2010 Safety of Machinery - General Principles for Design
EN 1953:2013 Atomising and spraying equipment for coating materials. Safety requirements

The object of the declaration described above is in conformity with the relevant Union harmonisation legislation: Directive 94/9/EC (until April 19th, 2016) and Directive 2014/34/EU (from April 20th, 2016)

Providing all conditions of safe use / installation stated within the product manuals have been complied with and also installed in accordance with any applicable local codes of practice.

Signed for and on behalf of
Carlisle Fluid Technologies:

DJ Hasselschwert
19-Jul-16

(Vice President: Global
Product Development)
Toledo, OH 43612

4-3194R-2

In this part sheet, the words **WARNING**, **CAUTION** and **NOTE** are used to emphasize important safety information as follows:

WARNING

Hazards or unsafe practices which could result in severe personal injury, death or substantial property damage.

CAUTION

Hazards or unsafe practices which could result in minor personal injury, product or property damage.

NOTE

Important installation, operation or maintenance information.

WARNING

Read the following warnings before using this equipment.



READ THE MANUAL

Before operating finishing equipment, read and understand all safety, operation and maintenance information provided in the operation manual.



OPERATOR TRAINING

All personnel must be trained before operating finishing equipment.



EQUIPMENT MISUSE HAZARD

Equipment misuse can cause the equipment to rupture, malfunction, or start unexpectedly and result in serious injury.



LOCK OUT / TAG-OUT

Failure to de-energize, disconnect, lock out and tag-out all power sources before performing equipment maintenance could cause serious injury or death.



AUTOMATIC EQUIPMENT

Automatic equipment may start suddenly without warning.



PRESSURE RELIEF PROCEDURE

Always follow the pressure relief procedure in the equipment instruction manual.



KEEP EQUIPMENT GUARDS IN PLACE

Do not operate the equipment if the safety devices have been removed.



KNOW WHERE AND HOW TO SHUT OFF THE EQUIPMENT IN CASE OF AN EMERGENCY



WEAR SAFETY GLASSES

Failure to wear safety glasses with side shields could result in serious eye injury or blindness.



INSPECT THE EQUIPMENT DAILY

Inspect the equipment for worn or broken parts on a daily basis. Do not operate the equipment if you are uncertain about its condition.



NEVER MODIFY THE EQUIPMENT

Do not modify the equipment unless the manufacturer provides written approval.



NOISE HAZARD

You may be injured by loud noise. Hearing protection may be required when using this equipment.

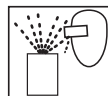

PROJECTILE HAZARD

You may be injured by venting liquids or gases that are released under pressure, or flying debris.



PINCH POINT HAZARD

Moving parts can crush and cut. Pinch points are basically any areas where there are moving parts.



STATIC CHARGE

Fluid may develop a static charge that must be dissipated through proper grounding of the equipment, objects to be sprayed and all other electrically conductive objects in the dispensing area. Improper grounding or sparks can cause a hazardous condition and result in fire, explosion or electric shock and other serious injury.



WEAR RESPIRATOR

Toxic fumes can cause serious injury or death if inhaled. Wear a respirator as recommended by the fluid and solvent manufacturer's Safety Data Sheet.



TOXIC FLUID & FUMES

Hazardous fluid or toxic fumes can cause serious injury or death if splashed in the eyes or on the skin, inhaled, injected or swallowed. LEARN and KNOW the specific hazards of the fluids you are using.



FIRE AND EXPLOSION HAZARD

Improper equipment grounding, poor ventilation, open flame or sparks can cause a hazardous condition and result in fire or explosion and serious injury.



MEDICAL ALERT

Any injury caused by high pressure liquid can be serious. If you are injured or even suspect an injury:

- Go to an emergency room immediately.
- Tell the doctor you suspect an injection injury.
- Show the doctor this medical information or the medical alert card provided with your airless spray equipment.
- Tell the doctor what kind of fluid you were spraying or dispensing.



GET IMMEDIATE MEDICAL ATTENTION

To prevent contact with the fluid, please note the following:

- Never point the gun/valve at anyone or any part of the body.
- Never put hand or fingers over the spray tip.
- Never attempt to stop or deflect fluid leaks with your hand, body, glove or rag.
- Always have the tip guard on the spray gun before spraying.
- Always ensure that the gun trigger safety operates before spraying.



PROP 65 WARNING

WARNING: This product contains chemicals known to the State of California to cause cancer and birth defects or other reproductive harm.

IT IS THE RESPONSIBILITY OF THE EMPLOYER TO PROVIDE THIS INFORMATION TO THE OPERATOR OF THE EQUIPMENT. FOR FURTHER SAFETY INFORMATION REGARDING THIS EQUIPMENT, SEE THE GENERAL EQUIPMENT SAFETY BOOKLET (77-5300).

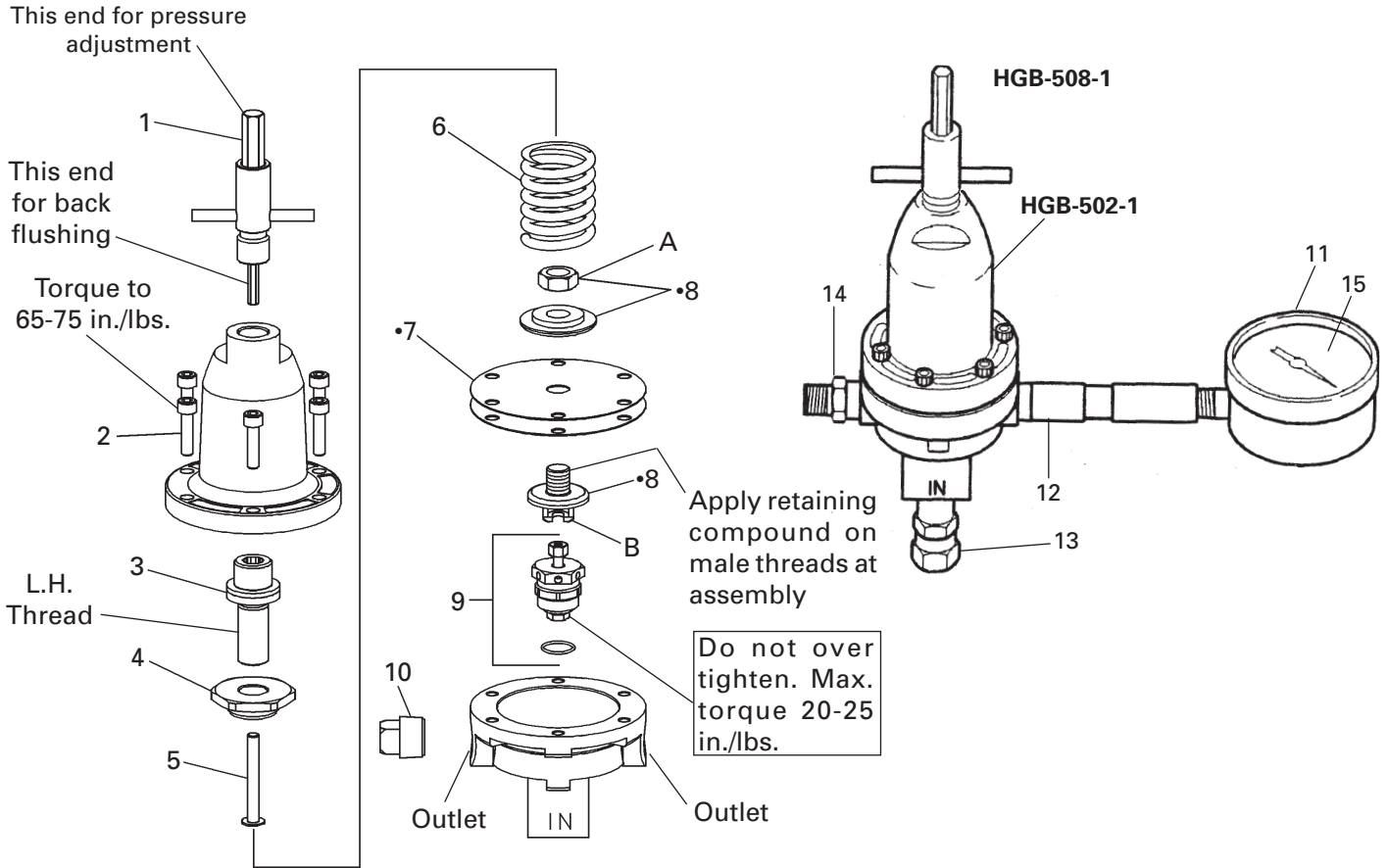

Parts List

Ref. No.	Replacement Part No.	Description	Individual Parts Req.
1	HGB-404-1	Adjusting Key	1
2	SSF-3167-K6	Cap Screw (Kit of 6)	6
3	HGB-408	Adjusting Screw Assembly	1
4	HGB-7	Adjusting Nut	1
5	HGB-403	Pin Assembly	1
6	HGB-13	Spring	1
+7	HGB-16-K10	Diaphragm Kit, Nylon II (Kit of 10)	2
•8	KK-4216	Diaphragm Hardware Kit	1
9	HGB-406-4-K	Valve Assembly Kit	1

Ref. No.	Replacement Part No.	Description	Individual Parts Req.
*10		S/S Plug, 3/8" NPT(M)	1
11	83-2727	Gauge (0-100#)	1
12	HGB-14	Riser Tube, Stainless Steel	1
13	PLH-6SN-6TSS	Swivel Fitting, S.S.	1
14	PLH-6-6TSS	Fitting, Stainless Steel	1
■15	83-2290	Glass Lens	1

• All kits contain parts shown plus retaining compound for use at assembly.

+ Kit contains 10 diaphragms. Only 2 are used in regulator. Diaphragms are only available in kit form.

■ Available separately. Order 83-2290.

* Purchase locally.

ACCESSORIES

HGB-14 Riser Tube

3/8" NPT(M) x 1/4" NPT(F) Stainless Steel, 3-1/2" for elevated mounting of gauge

83-2727 Air Pressure 0-100 PSI Gauge

1/4" NPT(M), 2-3/16" diameter, requires riser tube.

H-2008 Adapter

1/4" NPS(M) x 1/4" NPT(M) for adapting regulator to remote air control.

VA-527 Ball Valve S/S

3/8" NPS(M) x 3/8" NPT(M)

NOTES

NOTES

NOTES

WARRANTY POLICY

This product is covered by Carlisle Fluid Technologies' materials and workmanship limited warranty. The use of any parts or accessories, from a source other than Carlisle Fluid Technologies, will void all warranties. Failure to reasonably follow any maintenance guidance provided may invalidate any warranty.

For specific warranty information please contact Carlisle Fluid Technologies.

Carlisle Fluid Technologies is a global leader in innovative finishing technologies. Carlisle Fluid Technologies reserves the right to modify equipment specifications without prior notice.

DeVilbiss®, Ransburg®, ms®, BGK®, and Binks®
are registered trademarks of Carlisle Fluid Technologies, Inc.

©2018 Carlisle Fluid Technologies, Inc.
All rights reserved.

For technical assistance or to locate an authorized distributor,
contact one of our international sales and customer support locations.

Region	Industrial / Automotive	Automotive Refinishing
Americas	Tel: 1-800-992-4657 Fax: 1-888-246-5732	Tel: 1-800-445-3988 Fax: 1-800-445-6643
Europe, Africa, Middle East, India	Tel: +44 (0)1202 571 111 Fax: +44 (0)1202 573 488	
China	Tel: +8621-3373 0108 Fax: +8621-3373 0308	
Japan	Tel: +81 45 785 6421 Fax: +81 45 785 6517	
Australia	Tel: +61 (0) 2 8525 7555 Fax: +61 (0) 2 8525 7575	

For the latest information about our products, visit www.carlisleleft.com