

LUNA-MARK II -K GUN

Operation Manual (For GENERAL INDUSTRIES)

DEVILBISS

Important: Read and follow all instructions and SAFETY PRECAUTIONS before using this equipment
The gun body of this model is finished with special coating. Do not use wire-brush or metal-spatula for cleaning.
Do not inscribe letters on the gun body. It may cause the coating to peel off.

MODELS

LUNA2 - K- Air Cap No. - Fluid Tip Size – Type of Feed (P : Pressure)

(Ex.): LUNA2-K-PL1-FX-P ← (No. PL1 Air Cap – Tip Size FX (1.1mm) – Pressure Type)

SPECIFICATIONS

Maximum Working Air Pressure: 0.69 MPa, Maximum Working Fluid Pressure: 0.69 MPa

Chart.1

Air Cap No. Part Number	Tip size(mm)			Feed	Air consumption	Pattern width (mm)	Application	Fluid inlet	Air inlet	Weight (g)
	GY(0.8)	FX(1.1)	FF(1.4)							
PL1 LUNA2-3-PL1	○	○	○	Pressure LVMP	205ℓ/min	170	For General Industries	G1/4	G1/4	265
PL2 LUNA2-3-PL2	○	○	○	Pressure LVMP	205ℓ/min	220				
PL3 LUNA2-3-PL3	○	○	○	Pressure Conventional	240ℓ/min	210				

PL1•PL2 / •Spray distance 200mm •Air Pressure 0.2Mpa •Flow rate 200cc/min •Viscosity 20sec(HIS) •Tip size FX PL3 / •Spray distance 200mm •Air Pressure 0.29MPa •Flow rate 300cc/min
 •Viscosity 20sec(HIS) •Tip size FX

PARTS LIST

Chart.2

Ref No.	Part Number	Description	Qty
1	LUNA2-6	Retaining Ring	1
2	JJ-50-K5	Ring Seat	1
3	Refer Chart.1	Air Cap	1
4	Refer Chart.3	Fluid Tip	1
5	LUNA2-7	Baffle	1
6	LUNA-8-K5	Gasket	1
7	LUNA2-35SUS	Fluid Inlet	1
8	LUNA2-S-BODY	Gun Body	1
9	LUNA2-44	Pattern Valve	1
10	LUNA2-443	Valve Seal Kit	1
11	FUN-43	Air Valve	1
12	FUN-25-K5	Valve Spring	1
13	LUNA2-12	Air Valve Bushing	1
14	Refer Chart.3	Needle	1
15	FUN-14-K5	Needle Spring	1
16	LUNA2-13	Needle Adjusting Screw	1
17	FUN-463	Needle Packing	1
18	FUN-11-K3	Packing Gland	1
19	FUN-46-K10	E-ring Kit	1
20	FUN-45-K5	Bearing Stud	1
21	FUN-108	Trigger	1
22	LUNA2-42	Cheater Valve	1
23	LUNA2-30	Air Connector	1
24	LUNA2-34	Valve Seal Inserting Tool (Sold separately)	1

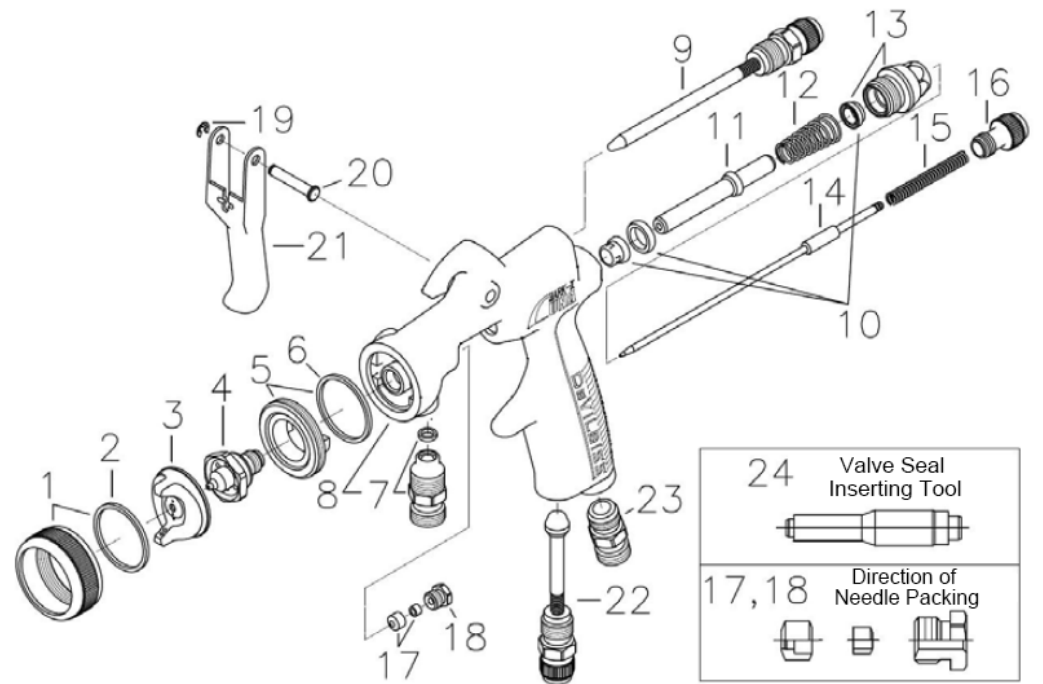

Chart.3

Description Size(mm)	Fluid Tip	Needle
GY(0.8)	LUNA2-4-GY-S	LUNA2-41-GY
FX (1.1)	LUNA2-4-FX-S	LUNA2-41-FZ
FF (1.4)	LUNA2-4-FF-S	LUNA2-41-FZ

Note) Ref. No. 24 (LUNA2-34) is needed for Ref.10 (LUNA2- 443) installation. When removing it, be careful not to damage the surface of seat where inserted. A damaged seat can lead to air leakage.

SAFETY PRECAUTIONS

This manual contains information that is important for you to know and understand. This information relates to USER SAFETY and PREVENTING EQUIPMENT PROBLEMS. Read and follow SAFETY PRECAUTIONS before using this equipment.

FIRE OR EXPLOSION HAZARD

1. When spraying, adequate exhaust must be provided to keep air free of accumulations of flammable vapors which may cause fire or explosion.
2. Smoking must never be allowed in the spray area.
3. Static electricity is generated and a static spark could be produced in the spray area. To prevent the risk of fire or explosion, ground without fail all conductive objects in the spray area.
4. Make it sure to use and ground hoses with static wire for spray gun operation. If improperly grounded, a static spark possibly produced may cause fire or explosion.
5. Fire extinguishing equipment must be provided in the spray area.
6. Solvents used for cleaning must have a flash point equal to or higher than that of the coating. Those for general cleaning must have flash points above 37.8°C (100°F) to prevent the risk of fire.

INHALING TOXIC SUBSTANCES

1. Toxic vapors and liquids are harmful to health. When spraying, adequate exhaust must be provided to keep the air free from accumulations of toxic materials and in the use at all times of respiratory protective equipment must be set compulsory.
2. Always wear eye protection when spraying or cleaning the equipment.
3. Certain materials may be harmful if contacted with the skin. Read all labels and safety performance data of the materials and solvents to be used. Appropriate clothes and gloves must be worn for spraying or cleaning the equipment.

MISUSE

1. Operators should be given adequate and appropriate training in the safe use and maintenance of this equipment.
2. Pressured liquids may injure eyes. Do not point the spray gun to any person.
3. Gravity or suction feed gun must not be used for pressure feed gun.
4. Parts with compressed air may damage the human body. Connect air hoses tightly by using a spanner so that air never leaks. If tightened loosely, hoses can be removed which may result in damaging the human body, objects to be coated and other equipment used together.
5. Parts with compressed air or under spring pressure may injure the human body. When replacing such parts, clean the spray gun by discharging the materials, discharge the air, remove air hose and fluid cup and then replace such parts by placing the gun flat. Eye protection must be worn when repairing the spray gun.
6. Do not use the gun above maximum working pressure (0.69MPa).

INSTALLATION

1. The air supplied to spray gun must be cleaned, in which any water, oil and solid material are removed. It is recommended to set up the Mist Separator and Air Transformer near the gun. The use of air not cleaned may cause coating troubles.
2. Connect fluid cup and air hoses tightly. If loose, hoses may disconnect, which may result in injuring the human body, damaging objects to be coated and other equipments used together.
3. Adjust Needle Packing (17) before use of a brand new gun. Tighten the Packing Gland (18) gradually and adjust the needle to move smoothly. Untighten until the Needle (14) is not well pulled back.

OPERATION

1. The recommended pressure of air supplied to gun is in a range of 0.24MPa~0.29MPa for conventional type, and 0.15MPa~0.24MPa for LVMP type. Do not exceed the maximum working air pressure for proper usage (0.69MPa).
2. Try with the pressure starting from around 0.2MPa, as the spraying pressure varies depending upon the inner diameter of gun, triggering distance, and materials etc.
3. The recommended spray distance is 180mm. If the spray distance is too far, good results will not appear.
4. In order to get uniform finishing, the spray gun should be held vertically toward the painting surface.

PREVENTIVE MAINTENANCE

1. Daily lubrication and cleaning is necessary to maintain the best condition of the gun.
2. To clean the gun body, wipe exterior with solvent dampened cloth. Do not submerge the gun body in solvent as any solids may get into the air passage and cause troubles.
3. Do not leave the gun with solvent remained in the fluid cup. Clean the spray gun after use with clean solvent and by emptying the cup. To clean the fluid cup after use, remove remaining paint through appropriate solvent and flush down any residual paint.
4. The Air Cap can be immersed in solvent and brushed down for cleaning. If orifices are clogged, use a toothpick to remove obstruction. Never use a steel wire or hard instrument. This will damage Air Cap and result in a distorted spray pattern.
5. Do not immerse any plastic parts in solvent for long time.
6. Certain portions of gun should be lubricated. Do not lubricate to any portion where not instructed. For lubrication, SSL-10 Gun Lube* is recommended (*Sold separately. Vegetable oil that does not repel paint materials).
7. The following portions should be lubricated regularly; Trigger Bearing Stud (20), Pattern Valve (9), threads of Cheater Valve (22) and Adjusting Screw (16), Air Valve (11) stem, and portion of Packing Gland (18) where Needle (14) comes in and out.
8. When installing Air Cap (3), make sure no foreign materials adhered on Retaining Ring (1) and thread of Baffle (5). Inject one drop of Gun Lube SSL-10.
9. Apply non-silicone grease lightly on Needle Spring (15) and Air Valve Spring (12). Do not apply too much grease as it may clog the air passage.

REPLACEMENT OF PARTS

Before replacing gun parts, remove materials from the gun for cleaning. Then release the air pressure in the gun and disconnect air hoses. All repairs should be made on a clean flat surface. Use only appropriate tools indicated for replacement of parts.

Fluid Tip (4) and Needle (14)

1. It is recommended to replace Fluid Tip (4) and Needle (14) as a set.
2. Loosen Pattern Valve (9) completely by turning the knob counterclockwise.
3. Remove Adjusting Screw (16) and Needle Spring (15) and then withdraw Needle (14) from the gun body.
4. Remove Retaining Ring (1) and Air Cap (3).
5. Remove Fluid Tip (4) by using socket wrench or offset wrench and Baffle (5) can also be removed.
6. When reassembling, it is recommended to replace Gasket (6) which is consumable.
7. Recommended torque of Fluid tip (4) is 15N·m.

Fluid Inlet (7) and Air Connector (23)

Fluid Inlet (7) and Air Connector (23) are fixed together with fluid packing. Use offset wrench for disassembling and reassembling. When reassembling, apply fluid packing to threads of gun body.

Pattern Valve (9) and Cheater Valve (22)

When disassembling and reassembling Pattern Valve (9) and Cheater Valve (22), turn the knobs completely counterclockwise and then disassemble or reassemble them.

Valve Seal Kit (10), Air Valve (11), Valve Spring (12) and Air Valve Bushing (13)

Valve Seal Inserting Tool (24) is required for replacing Valve Seal Kit (10). When replacing Valve Seal Kit (10), be careful not to damage the surface of seals of Gun Body (8), Air Valve Bushing (13) and Air Valve (11) to prevent air leakage.

1. Remove Needle Adjust Screw (16) and Needle Spring (15) and then withdraw Needle (14) from the Gun Body (8).
2. Remove Air Valve Bushing (13) by using 13mm offset wrench.
3. Withdraw Valve Spring (12) and Air Valve (11) from the gun body.
4. Withdraw Valve Seal Kit (10), being careful not to damage where fitted to.
5. Insert each seat by using Valve Seal Inserting Tool (24).
6. Insert Air Valve (11) to the bottom end, being careful not to damage the seat, and then insert Air Valve Spring (12).
7. Install Air Valve Bushing (13) by using offset wrench.



Needle Packing (17)

1. Install Needle Packing (17) in the direction shown per drawing.
2. Adjust Needle Packing (17). Tighten the Packing Gland (18) gradually. To adjust the needle moving smoothly, untighten a little where the Needle (14) is not well pulled back.

SERVICE CHECKS

Normal spray pattern

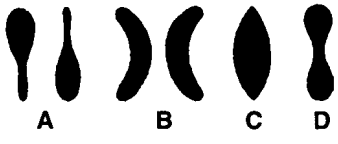

problem	Cause	Correction
Will not spray	No pressure to gun. Adjusting Screw (16) not properly adjusted.	Check air and material lines. Adjust.
Improper spray pattern 	A,B - Material build up on the Air Cap or Fluid Tip. C,D - Incorrect fluid delivery or viscosity.	A,B - Clean the Air Cap or Fluid Tip. C,D - Adjust.
Jerky or fluttering spray 	Insufficient material in the cup or Loose connector. Gun fluid passage plugged. Worn Needle Packing (17). Loose or damaged Fluid Tip (4).	Fill cup or tighten the Connector. Clean. Replace. Tighten or replace.
Fluid leaking from Packing Gland (18)	Loose Packing Gland (18). Worn or damaged Needle Packing (17).	Adjust Packing Gland (18). Replace.
Dripping from fluid tip	Worn or damaged Fluid Tip (4) or Needle (14). Stuck Needle Packing (17) or Needle (14). Tight Packing Gland (18). Loose Adjusting Screw (10).	Replace. Lubricate. Adjust. Tighten.

ACCESSORIES

Part No.	Description	Part No.	Description
DAH-10	Air Hose Set (10m)	HAV-502-B	Air Adjusting Valve with Gauge
DPH-10-2	Fluid Hose Set (10m)	SSL-10	Gun Lube (60mℓ)
DPT-20H	Pressure Tank (20ℓ)	42884-214-K5	Cleaning Brush (kit of 5)

DEVILBISS DIVISION

CFT Ransburg Japan KK

15-5, Fukuura 1-chome, Kanazawa-ku, Yokohama, Kanagawa Japan 〒236-0004
TEL : +81-45-785-6434 / FAX : +81-45-785-6517

HP <http://www.carlisleft.co.jp>

©DEVILBISS is a registered trademark of Carlisle Fluid Technologies
©Jupiter is a registered trademark of CFT Ransburg Japan KK.



©2017 Carlisle Fluid Technologies.

2017-07- LUNA-MARK II -K